



PD-Ai

Air Shower Integrated AHU

PBSC provide installation, servicing, technical advice, product selection and demonstrations for clean controlled environments with **Innovation, Design** and **Quality** at the heart.

PBSC manufacture high quality clean room, high containment and material decontamination products. When you need areas and staff to be contamination free and protected from pathogens, you need dependable equipment which will maintain critical biosafety levels, achieve sterility and protect data reliability.

Complying with local and global regulations **PBSC's** products can be designed to meet your specific requirements. Over 30 years knowledge and competence within the specialist sectors, always going through extensive research and development and offering accurate assistance during project planning to consultants, architects and end users to deliver successful projects.



Innovation

Incorporating your requirements to create product ranges to exceed expectations



Design

Leading the way with pioneering design, ensuring customer requirements are achieved



Quality

Delivering high quality products for over 30 years, with rigorous testing and inspection

PBSC is the accepted benchmark by which others are measured...

The search for innovative design, an eye for detail and advanced manufacturing techniques has seen **PBSC** gain a deserved reputation as the premier supplier within cleanroom environments.

Supporting the customer throughout the process continuing to meet the growing challenges and striving for continual improvement with our ISO 9001 QA processes independently audited and updated on a regular basis.

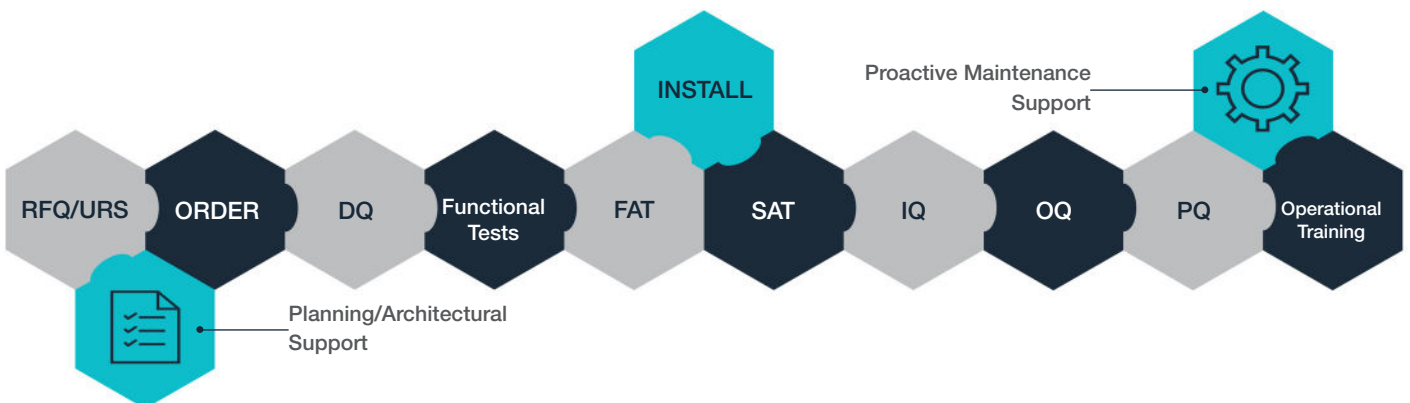



Description



PBSC's personnel air shower comes in two designs, one with the integrated Air Handling Unit (AHU) on the top of the shower and with a separate AHU which has "Safe Change" filters. Both options remove particles from the operative with high-velocity air jets. The integrated unit is designed to remove non-hazardous particles on entry into a controlled area.

The air shower is the latest design from PBSC which has been continually improved over the years and features either stainless-steel or powder-coated steel construction with interlocked float and toughened glass personnel doors. The shower has the final assembly in place and requires no cranes or special access on-site as the largest piece will fit through a single doorway.

Maximum clear opening – the door design has been refined to provide a maximum clear entry width with the frame finishing flush to the internal panels. (straight-through design only).

There are 9 x adjustable stainless-steel nozzles on both side walls, 18 nozzles in total.

As the operative enters the shower, the PLC automatically turns on the high-performance 24VDC LED light, which is powered by the PLC (no mains power in the shower cubicle).

The lowest nozzle is only 21.5cm from the finish floor level with a low-level return on each wall panel to the AHU built into the top of the shower cubicle.

When the shower cycle is started by the operative, the shower controls lock the doors and run the fans to provide

the airflow below. (Note the shower has a low power usage with a highly efficient fan, the total power requirement is only 10Amps @ 110 – 230V, 50 to 60HZ, 1 Ph.)• Clean Filter – 150 Pa• 32m/s at 5cm from the nozzles

- Dirty Filter – 300 Pa
- 28 m/s at 5cm from the nozzles

The system is available with a range of control panel options, the standard is a Siemens Logo, which can be provided with an Allen Bradley PLC or a Siemens S1200 PLC. The S1200 PLC comes with a touch screen in the shower (or on the PLC cabinet) to show the shower status alarms, which can be seen and cleared from the screen.

Available with Safe Change – Please contact PBSC for more information

[The PBSC Decontamination Shower has been proven to minimise risks...](#)

Options



- Right angles design.
- Air knife (requires S1200 PLC upgrade).
- Automated doors.
- S1200 PLC upgrade.
- 304 or 316 stainless steel construction.

Door A Entry

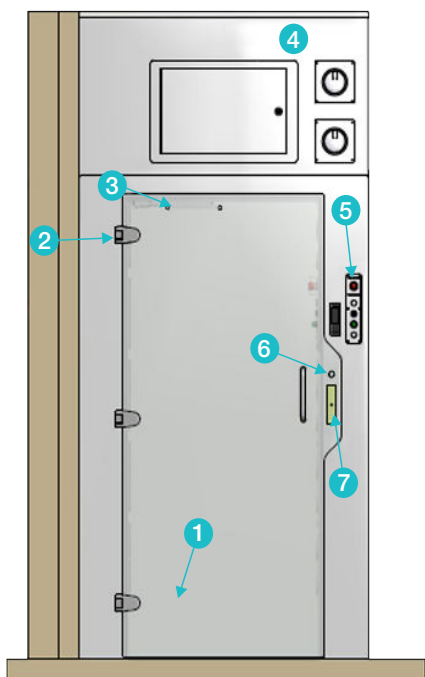

Side View

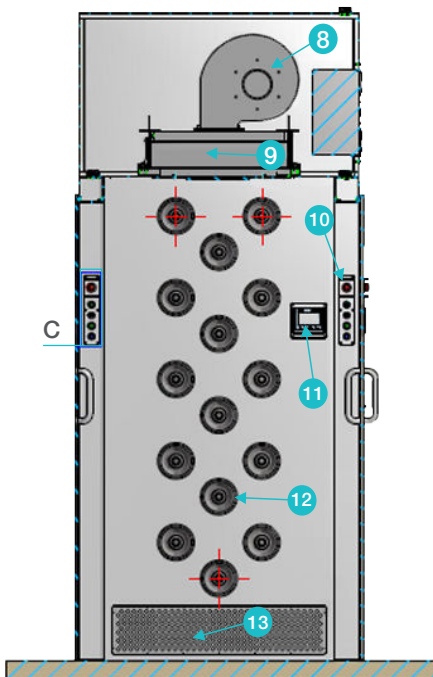

Door B Entry

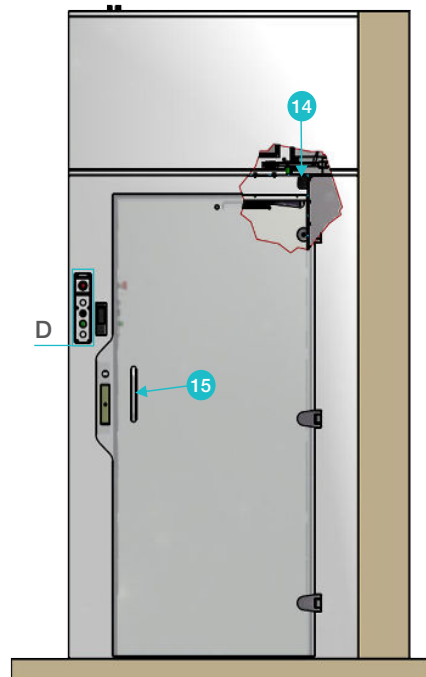

Plan View

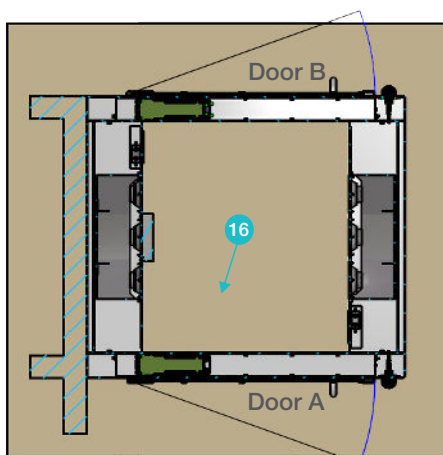

Detail C

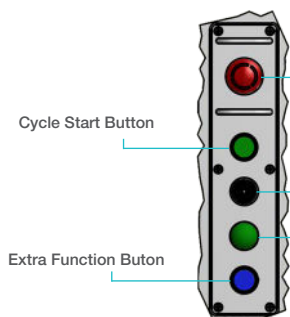

Internal Panel

Detail D

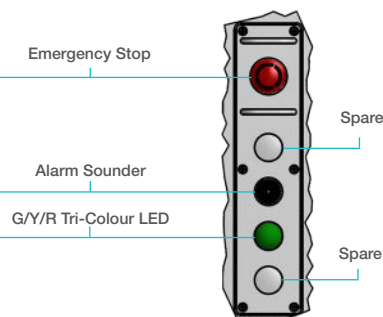

External Panel

- 1. Thick Clear Toughened Glass
- 2. Stainless Steel Hinges
- 3. Concealed Door Closing Arm
- 4. Integrated Electrical Panel
- 5. External Controls and Indicators
- 6. Proximity Switch
- 7. Maglock
- 8. Fans

- 9. HEPA Filter
- 10. Internal Controls and Indicators
- 11. Siemens Display
- 12. Air Nozzle Jets
- 13. Low-Level Return Vents
- 14. Ceiling Mounted PIR Sensor
- 15. Stainless Steel "D" Handles
- 16. LED Panel and Service Access

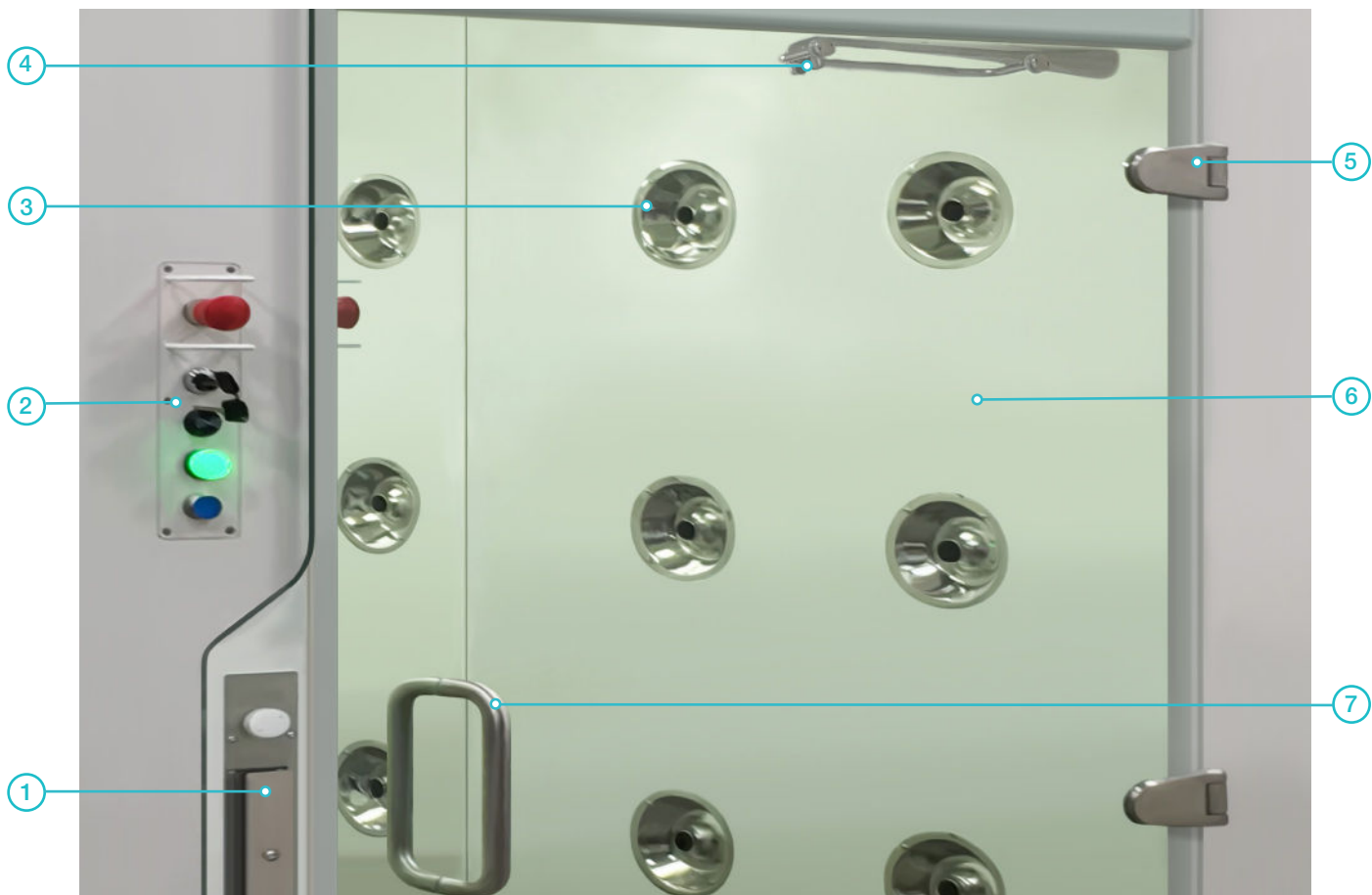

Key Features



- PLC controlled internal 24VDC LED light.
- High velocity from nozzles.
- Adjustable stainless-steel nozzle, no performance loss with different positions.
- Efficient power use, only 10A, 1Ph required (110 or 230V).
- Frameless glass door sets – maximum clear opening.
- **PBSC** concealed closer system.
- Adjustable air supply nozzle.
- **PBSC** solid stainless-steel hinge.
- Tinted toughened frameless glass.
- Stainless-steel pull handles.

- ① Flush Maglock
- ② Shower Controls
- ③ Adjustable air supply nozzle
- ④ **PBSC** concealed closer system
- ⑤ **PBSC** solid stainless-steel hinge
- ⑥ Tinted toughened frameless glass
- ⑦ Stainless-steel pull handles

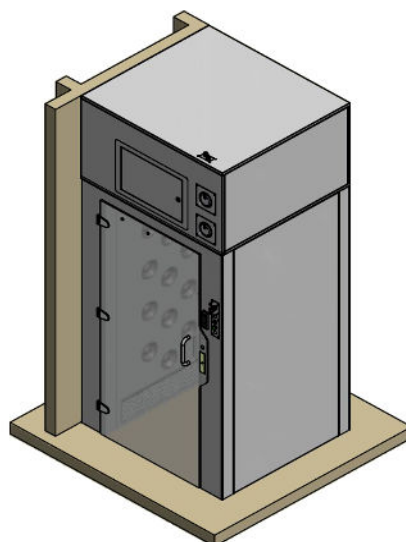

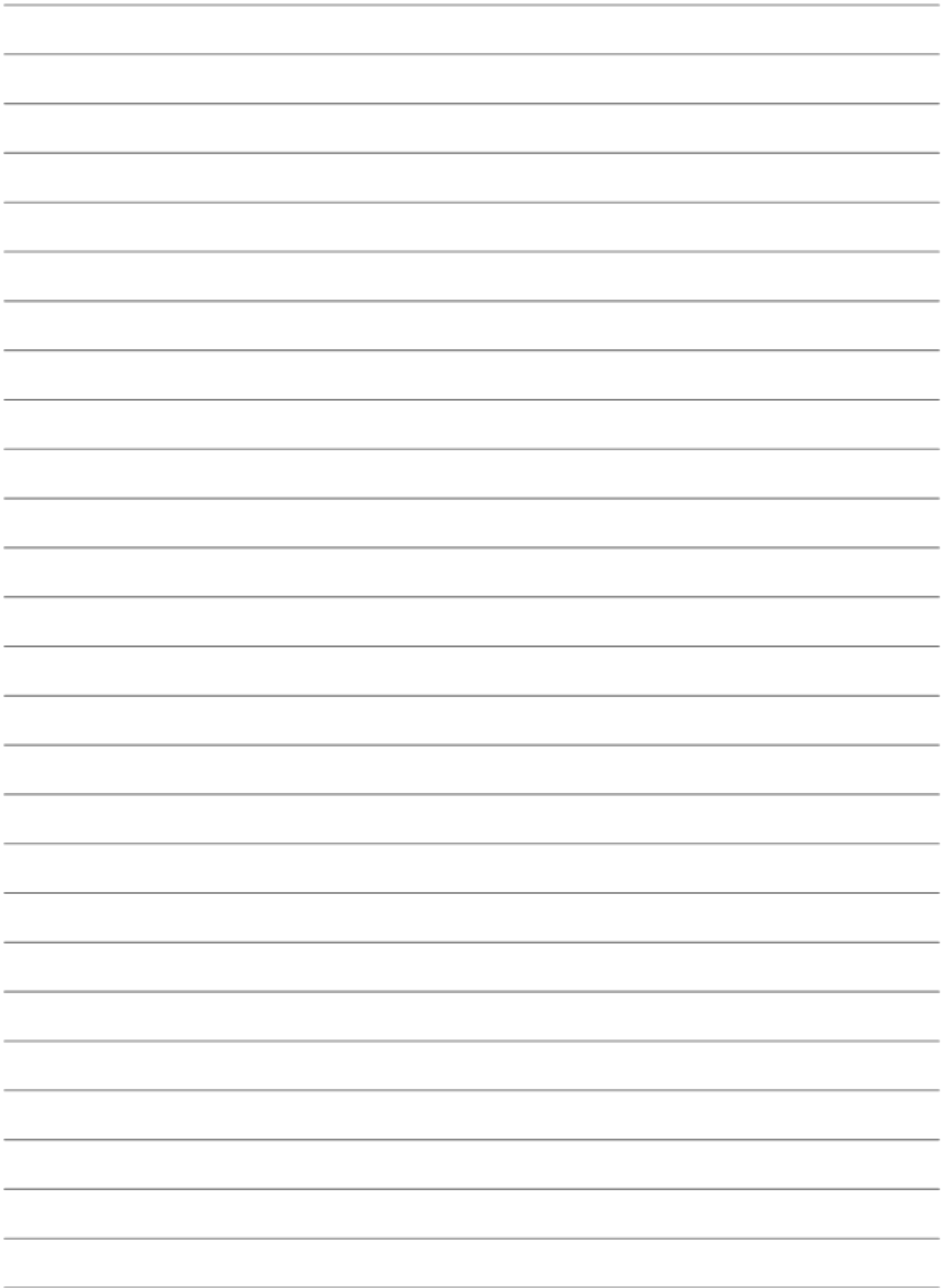

PBSC Staying in Control of Controlled Environments

Established in 1987 PBSC has become one of the leading manufacturers of clean room, high containment and material decontamination products throughout the world and having the extensive product range and bespoke designs and assembly capabilities can meet customers needs.

Providing high quality products and services to the pharmaceutical, medical research, high containment and hospital sectors, offering quick and accurate assistance during project planning to consultants, architects and end users.

PBSC have agents and representatives in most countries to provide excellent local support and logistical services to make sure your products arrive on time.

Products include;

- Clean Room Doors
- Pneumatic Inflatable Seal /Airtight Door Sets
- Mechanical Seal / Airtight Doors
- Material Decontamination Chambers
- Transfer Hatches / Cleanroom Pass Through
- Fogging Showers / Mist Showers
- Air Showers

www.pbsc.co.uk
www.pbsc-inc.com

PD-Ai10823

PBSC reserve the right to introduce changes in performance, configuration and technology, dimension, weights and materials in the course of technical progress. Images may not be accurate