



PD-F

Fogging Shower

PBSC provide installation, servicing, technical advice, product selection and demonstrations for clean controlled environments with **Innovation, Design** and **Quality** at the heart.

PBSC manufacture high quality clean room, high containment and material decontamination products. When you need areas and staff to be contamination free and protected from pathogens, you need dependable equipment which will maintain critical biosafety levels, achieve sterility and protect data reliability.

Complying with local and global regulations **PBSC's** products can be designed to meet your specific requirements. Over 30 years knowledge and competence within the specialist sectors, always going through extensive research and development and offering accurate assistance during project planning to consultants, architects and end users to deliver successful projects.



Innovation

Incorporating your requirements to create product ranges to exceed expectations



Design

Leading the way with pioneering design, ensuring customer requirements are achieved



Quality

Delivering high quality products for over 30 years, with rigorous testing and inspection

PBSC is the accepted benchmark by which others are measured...

The search for innovative design, an eye for detail and advanced manufacturing techniques has seen **PBSC** gain a deserved reputation as the premier supplier within cleanroom environments.

Supporting the customer throughout the process continuing to meet the growing challenges and striving for continual improvement with our ISO 9001 QA processes independently audited and updated on a regular basis.

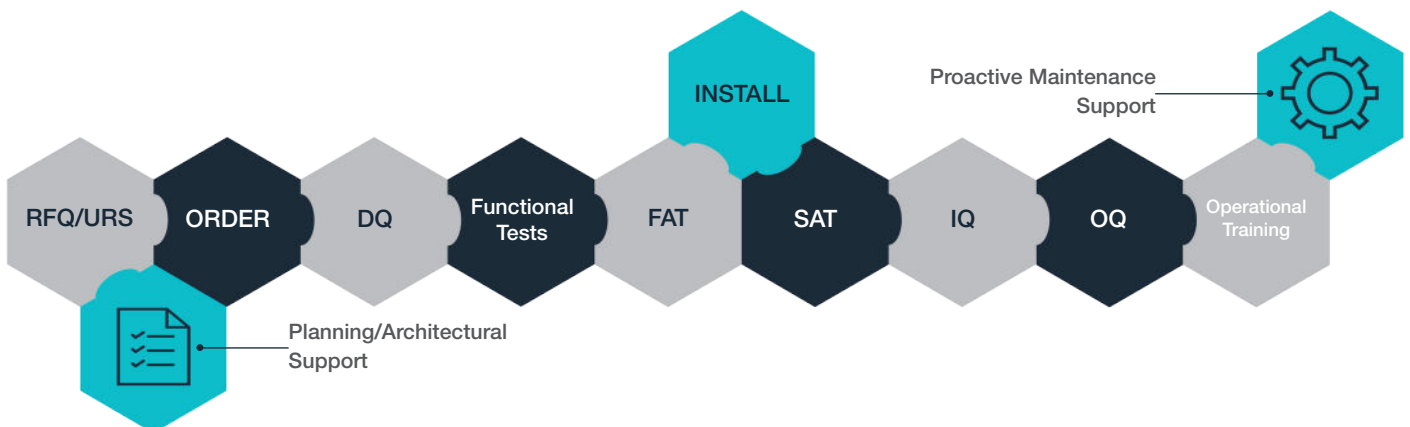

Description



The fogging Shower by **PBSC**, also referred to as a mist shower and Ultrasonic Shower, effectively provides encapsulation or removal of powder from an operative's suit and has been assessed by SafeBridge Consultants Inc.

The **PBSC** fogging shower cycle uses 5 to 10-micron water droplets to encapsulate API particles with minimal wetting through the operator's PPE suit.

Reductions in surface concentrations can be up to 800 times less than the starting contamination levels. Airborne particles around the operative and during de-gowning are also significantly reduced.

The decontamination fogging shower is supplied with factory-tested PLC controls and a utility control panel. The control cabinets can be located above or next to the shower with a prewired cable for ease of site electrical installation.

The shower comes equipped with easily replaceable parts that are supplied on plugs to make replacement of spare parts quick and easy so that in the unlikely event of component failure down time is minimised.

The system is available with various PLC options, including standard options of a Siemens LOGO PLC (with the choice of a remote 'TDE' PLC screen if required) or a Rockwell (Allen-Bradley) MLX1100 PLC with PanelView 800 HMI 4" colour touchscreen.

The PLC comes with a touch screen in the shower (or on the PLC cabinet) displaying the shower status, alarms can be seen and cleared from the screen and the screen allows various cycle recipes to be stored and accessed by the Supervisor Level password.



The **PBSC** fogging shower is a floor-mounted personnel shower used regularly or during emergencies. The shower's automated cycle produces a fine fog, used to encapsulate powders (typically APIs) usually on disposable operatives suits.

In the case where the operative's suit is reusable, and the powder is to be removed after encapsulation, the optional coarse fog rinse cycle can be executed after encapsulation, removing the powder without impacting the suit.

If needed, a final air shower cycle can be included. This involves installing air nozzles to two of the shower walls with supply and return ducting behind the shower walls. This air wash helps to reduce the amount of liquid on the suit and offers a quick air change of the shower cubical.



Filter Option

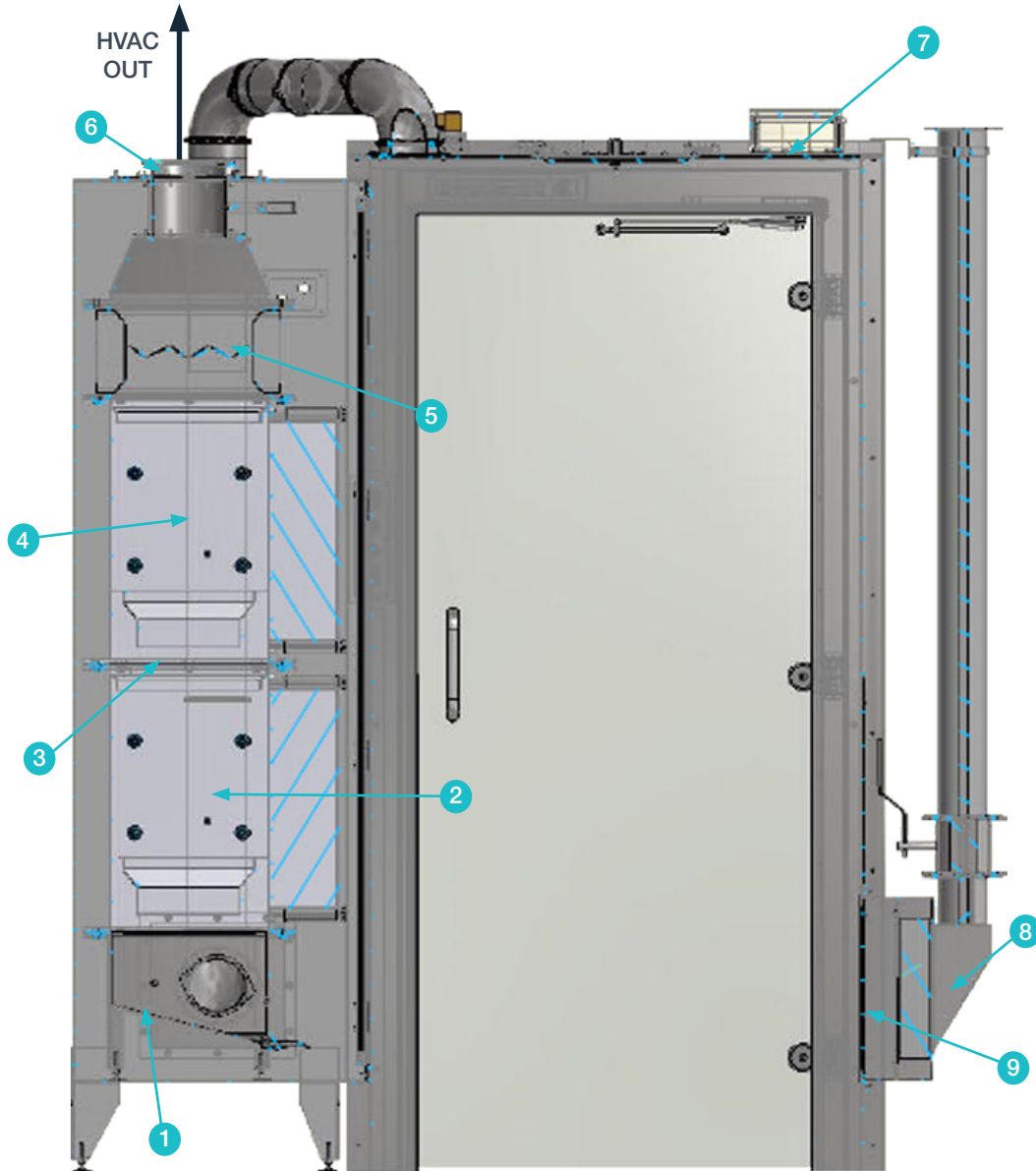

- 1...Stainless Steel Drip Tray
- 2...Coalescent Filter
- 3...Pressure Tapping Points Before & After Each Filter
- 4...H14 HEPA Filter
- 5...Manual Opposed SS Blade Damper

- 6...Ø150 Isolation Damper
- 7...Junction Box
- 8...HVAC Inlet H14 Filter
- 9...Louvered Inlet Cover

Options



- Garment bag-out chutes
- Folding shelves
- Wash gun with hose
- Breathing air supply point
- Dosing pump - for chemical addition to fog water, with adjustable proportional dosing rate
- CIP System with 360 spray ball - operate automatically from PLC timer or manually
- Emergency deluge shower and/or eyewash station
- Rinse cycle (reusable garments only) - either from "Coarse" fog nozzles or water sprays
- Air shower cycle (after rinse cycle only)
- HEPA filter with coalescent pre-filter on HVAC exhaust from shower, with safe change option
- Construction in grade 304 or 316 stainless steel

- Right angle design (entry and exit doors at 90)
- 3 or 4 door shower configurations, to interface with multiple rooms
- Shower sized for 1, 2 or more operatives
- Platform for de-gowning
- Privacy option - to keep shower doors locked whilst operative is de-gowning after showering
- Range of optional external control input options including fire alarm override, door interlocks, HVAC running (with shower alarm) and remote cycle start
- Optional external control outputs for common fault/ alarm and shower door positions
- Drainage options - self swab, central drain or side off-take drain



Key Features



- SafeBridge Assessment on performance
- Efficient usage of water to minimise liquid waste
- Air and water pressures to the fogging nozzles are monitored by the PLC
- Frameless glass door sets
- All cycle stage timers are user adjustable
- PLC controlled LED light
- Emergency override buttons
- Large range of options available

- ① Stainless-steel surfaces with no visible fixings
- ② PBSC solid stainless-steel hinge
- ③ 10mm toughened frameless glass
- ④ PBSC concealed closer system
- ⑤ Magnetic lock and proximity switch
- ⑥ Fogging nozzle
- ⑦ Smooth joint to the ceiling panel

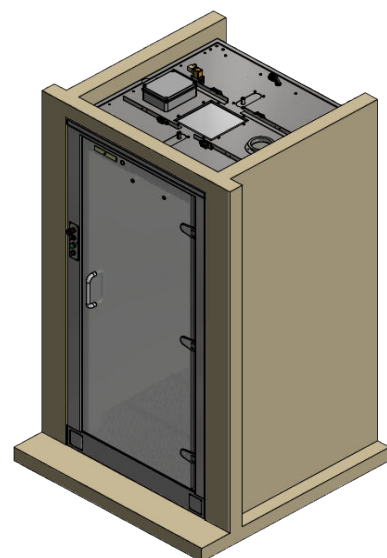



PBSC Staying in Control of Controlled Environments

Established in 1987 PBSC has become one of the leading manufacturers of clean room, high containment and material decontamination products throughout the world and having the extensive product range and bespoke designs and assembly capabilities can meet customers needs.

Providing high quality products and services to the pharmaceutical, medical research, high containment and hospital sectors, offering quick and accurate assistance during project planning to consultants, architects and end users.

PBSC have agents and representatives in most countries to provide excellent local support and logistical services to make sure your products arrive on time.

Products include;

- Clean Room Doors
- Pneumatic Inflatable Seal /Airtight Door Sets
- Mechanical Seal / Airtight Doors
- Material Decontamination Chambers
- Transfer Hatches / Cleanroom Pass Through
- Fogging Showers / Mist Showers
- Air Showers

www.pbsc.co.uk
www.pbsc-inc.com

AR-F10823

PBSC reserve the right to introduce changes in performance, configuration and technology, dimension, weights and materials in the course of technical progress. Images may not be accurate. Some of the information/images/equipment described or shown may only be available at extra cost. Features & specifications will vary. Please contact PBSC for specific design options.